

# CONTROLS APPENDIX

## ¼ INCH JACK INPUT CONNECTION

### PICKUP SELECTOR SWITCHES

### HOW VOLUME AND TONE CONTROLS WORK:

### ELECTRONIC SWITCH IN THE STEALTH PLUS CIRCUIT BOARD

## INPUT JACK CONNECTION WITH SUSTAINIAC INSTALLED

When you insert a mono plug into a stereo jack, the RING terminal gets shorted out to GROUND. This is because the mono plug has no RING terminal. Therefore, the ring terminal of the jack connects to the shell (shield, or ground connection) of the plug.

## INSERTING A MONO PLUG INTO A STEREO JACK

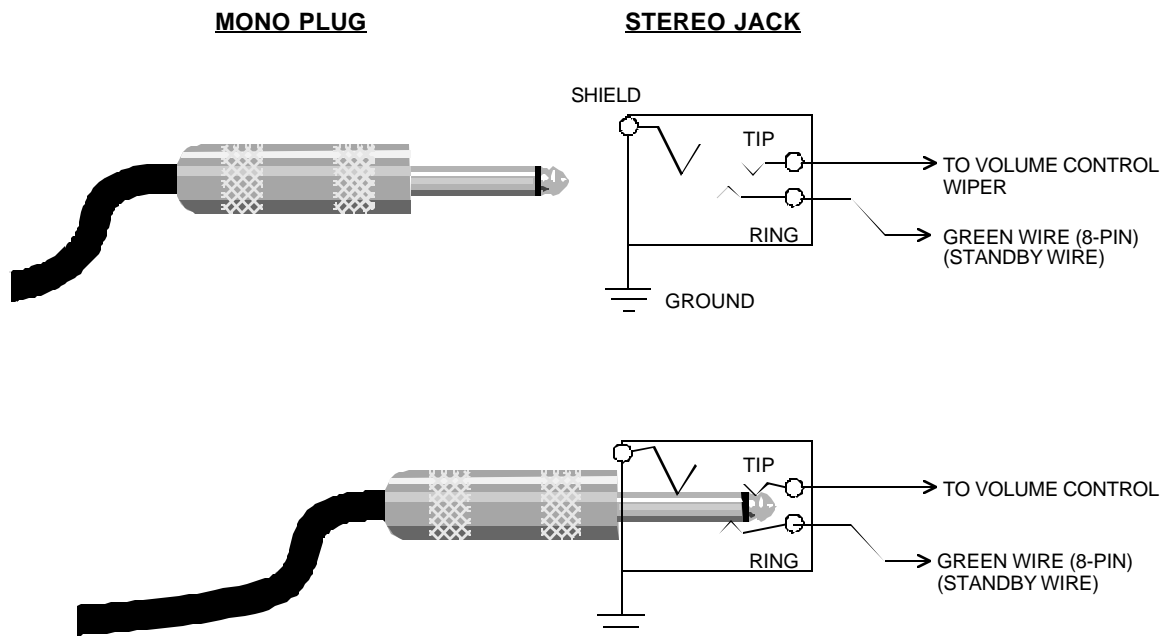

## APPENDIX: ABOUT PICKUP SELECTOR SWITCHES

Proper connection of the pickup selector switch is absolutely necessary for proper sustainer operation. Your pickup selector will be rewired during your Sustainiac installation.

When the Sustainiac is ON, *only the bridge pickup must function*, regardless of the setting on the pickup selector switch. The selector switch is wired so that this condition will happen. The electronic switch on the Sustainiac Stealth Plus circuit board is also used for this purpose. See ELECTRONIC SWITCH FUNCTION description in the DETAILED SUSTAINIAC OPERATION section for how the Sustainiac electronic switch works.

For all 5-position selector switches, the bridge pickup gets its own switch POLE (section). The middle and neck pickups get their own section. Neck and middle pickups will share the same section on a standard 2-pole switch ("CRL" or import 5-way). Or they will get their own separate sections on a 4-pole "Superswitch" or VLX-91 switch for Ibanez Jem guitars.

**Our Strat and "shredder" guitar drawings mostly use the standard "CRL" type output switch** that Strats have used from the beginning. Many Strat knockoffs and shredder type guitars use similar switches having different pinout (an "in-line" contact arrangement). The CRL and IN-LINE pickup selectors are similar electrically. They differ in the way the switch is arranged mechanically. The CRL switch has redundant contacts that "sandwich" the rotating contactor between redundant contacts. This makes a reliable, long-life switch. The IN-LINE switches aren't as reliable, as they generally don't have this redundant contact feature. See the following two diagrams for CRL and IN-LINE switch function and construction.

The "A" and "B" sections each have 4 contacts. The two sections, A and B are identical. They work in unison as you move the lever between positions 1,2,3,4 and 5. The COMMON terminals (labeled "C-A" and "C-B" connect sequentially to their respective 1,2,3 terminals as shown in the chart.

The bridge pickup is wired directly to the 1A contact of the CRL switch and also the IN-Line switch. The 2-A and 3-A terminals are not connected to anything. The neck pickup (or neck preamp output wire, blue, 8-pin connector) connects to the 3B contact. The middle pickup connects to the 2B contact.

See the next page for drawings of both the CRL and the IN-LINE switches.

## CRL-TYPE SWITCH (STRAT,<sup>®</sup> SHREDDER ETC., 5-POSITION)

Back of switch shown here.  
Lever points down into page.

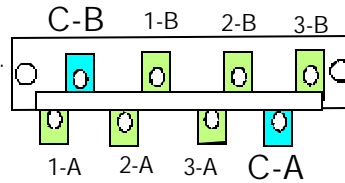

The CA and CB (Common) terminals connect sequentially to terminals 1-3 as the lever is moved between positions 1-5.

LEVER POSITION	C-A contactor	C-B contactor	PICKUP SELECTION
1	1-A	1-B	bridge
2	1-A and 2A	1-B and 2B	bridge + middle
3	2A	2B	middle
4	2-A and 3A	2-B and 3B	neck + middle
5	3A	3B	neck

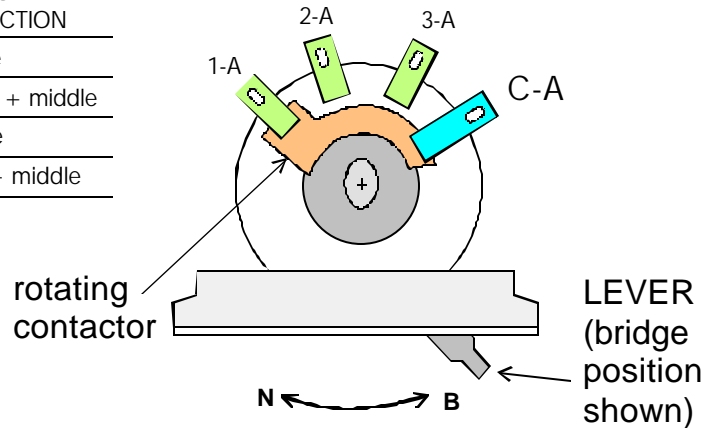

**The IN-LINE type switch is electrically identical to the CRL type:**

### IN-LINE TYPE SWITCH (5-POSITION).

Similar in function to CRL type, except the contacts are all in a straight line

Back of switch shown here.  
Lever points down into page.

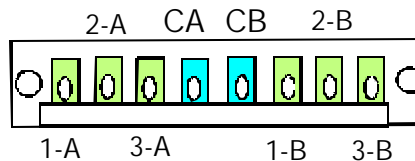

The CA and CB (Common) terminals connect sequentially to terminals 1-3 as the lever is moved between positions 1-5.

LEVER POSITION	C-A contactor	C-B contactor	PICKUP SELECTION
1	1-A	1-B	bridge
2	1-A and 2A	1-B and 2B	bridge + middle
3	2A	2B	middle
4	2-A and 3A	2-B and 3B	neck + middle
5	3A	3B	neck

**The Sustainiac ELECTRONIC SWITCH** is located on the Stealth PLUS circuit board. It is connected to the pickup selector using 3 wires on the 10-pin connector: **WHITE** (connects to bridge pickup), **BLUE** (connects to the C-B COMMON terminal), and **ORANGE** (connects to the C-A COMMON terminal) and also to the top of the **VOLUME CONTROL**. See **SUSTAINIAC ELECTRONIC SWITCH** diagram below.

When the sustainer is turned **OFF**, the switch electronically connects the **ORANGE WIRE** to the **BLUE WIRE**. In this configuration, all the guitar pickups function normally. When you turn the sustainer **ON**, the **ORANGE** wire disconnects from the **BLUE** wire (disconnecting the neck, middle pickups from the volume control). The **ORANGE** wire connects to the **WHITE** wire (bridge pickup). Now, the top of the volume control is directly connected to the **BRIDGE PICKUP**. Moving the selector switch lever to other positions has no effect. The bridge pickup remains connected.

### SUSTAINIAC<sup>®</sup> STEALTH PLUS ELECTRONIC SWITCH OPERATION AND WIRE FUNCTION DESCRIPTION

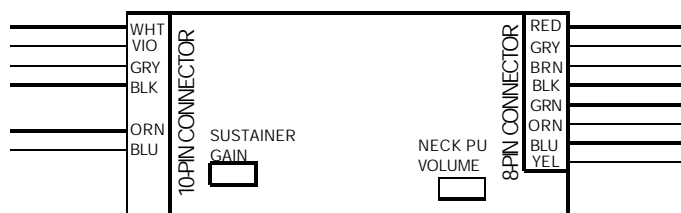

#### INTERNAL ELECTRONIC PICKUP SWITCH SCHEMATIC (Switch terminals pin out to the **10-pin connector**)

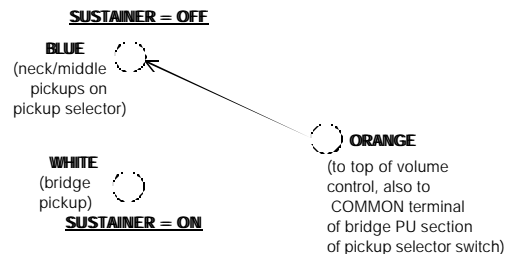

#### 10-PIN CONNECTOR

- WHITE: Sustainer input. Connects to bridge pickup "hot" wire
- VIOLET/GRAY: Forces Harmonic mode when connected together (twist together and move away from guitar signal wires to prevent grunge in signal.)
- BLACK: Signal Ground (low current ground); connects to pot bodies
- ORANGE: electronic pickup switch "common" terminal (on circuit board)  
Connects to BLUE wire (neck, middle pickup signal) when sustainer OFF  
Connects to WHITE wire (bridge pickup signal) when sustainer ON
- BLUE: Connect this to Middle/Neck pickup common terminal on pickup selector switch  
(when sustainer ON, M/N pickup signals automatically replaced by bridge pickup signal)

#### 8-PIN CONNECTOR

- RED: Connects to +9 volts
- GRAY: Connects to Driver RED wire for bridge pickup having (-) on pullaway. Connects to driver BLACK wire for reverse polarity pickups, such as EMG.
- BROWN: Driver amplifier output, connects to driver (red) through power switch and harmonic "Mix mode" capacitor.
- BLACK: Power ground. This wire must be connected to a pot body (signal ground), and ALSO must be connected to the battery (-) terminal.  
The battery (-) terminal and the black POWER GROUND wire should both be connected to the same physical place on a pot body. Otherwise, grunge can be introduced into the guitar output signal.
- GREEN: Standby wire. Connect to ground to turn on pickup amplifier, and place sustainer in Standby (battery current is 3-5 milliamps in Standby).  
This wire is connected to the "ring" terminal of the output jack, which is connected to Ground when you plug a mono plug into the jack.
- ORANGE: Input to driver preamp circuit (amplifies driver signal when sustainer is off, making driver an active neck pickup). Orange wire is connected to driver black (or red in case of "backward polarity" pickups, such as EMG) wire when ON/OFF switch is set to OFF position.
- BLUE: Output from driver preamp circuit (This is the neck pickup signal). Goes to "neck pickup" terminal of pickup selector switch, or in the case of guitars not having a middle pickup, is normally connected to the blue wire on the 10-pin connector.
- YELLOW: Connect to ground to turn sustainer ON. This is done when you turn the ON/OFF switch to ON.

#### POWER CONSUMPTION:

- STANDBY: Battery current is 3-5 milliamperes in Standby (whenever guitar cord is plugged in)
- RUN: Battery current is 40-60 milliamperes for most notes. Some notes in Harmonic Mode will be 10-50 ma.

When the Sustainiac battery is removed, the **ELECTRONIC SWITCH ORANGE** wire connects to *both* the **WHITE** and **BLUE** wires. Therefore, with no battery power to the circuit board, the bridge pickup is *always present*.

**The 3-position CRL switch** (Tele's and other 2-pickup guitars is shown below). This 3-position CRL was used on early Strats, but was eventually changed by Fender because so many Strat players liked the 2 and 4 positions. It is identical to the 5-position CRL, except that it has no mechanical detents for positions 2 and 4. Early Strat players used to "balance" the lever at the "in-between" (2 and 4) positions. Fender eventually decided to add the mechanical detents, and made the more useful switch that we have today.

For 2-pickup guitars, the 1A and 2A terminals are connected together using jumper wires, and the bridge pickup is connected to the 1A terminal. Also, the 2B and 3B terminals are jumpered together, and the neck pickup is connected to the 3B terminal. This connection blends the bridge and neck pickups in position 2, when the sustainer is turned OFF.

For 2-pickup guitars, the ORANGE wire (common terminal of the ELECTRONIC SWITCH) connects to the NECK PICKUP TERMINAL of the 3-position pickup switch. This arrangement allows the neck pickup to be selected when the sustainer is OFF, and when the sustainer is ON, the electronic switch forces the bridge pickup to be selected at all 3 positions of the pickup selector switch.

3-POSITION CRL-TYPE SWITCH. (TELE<sup>®</sup>-STYLE)

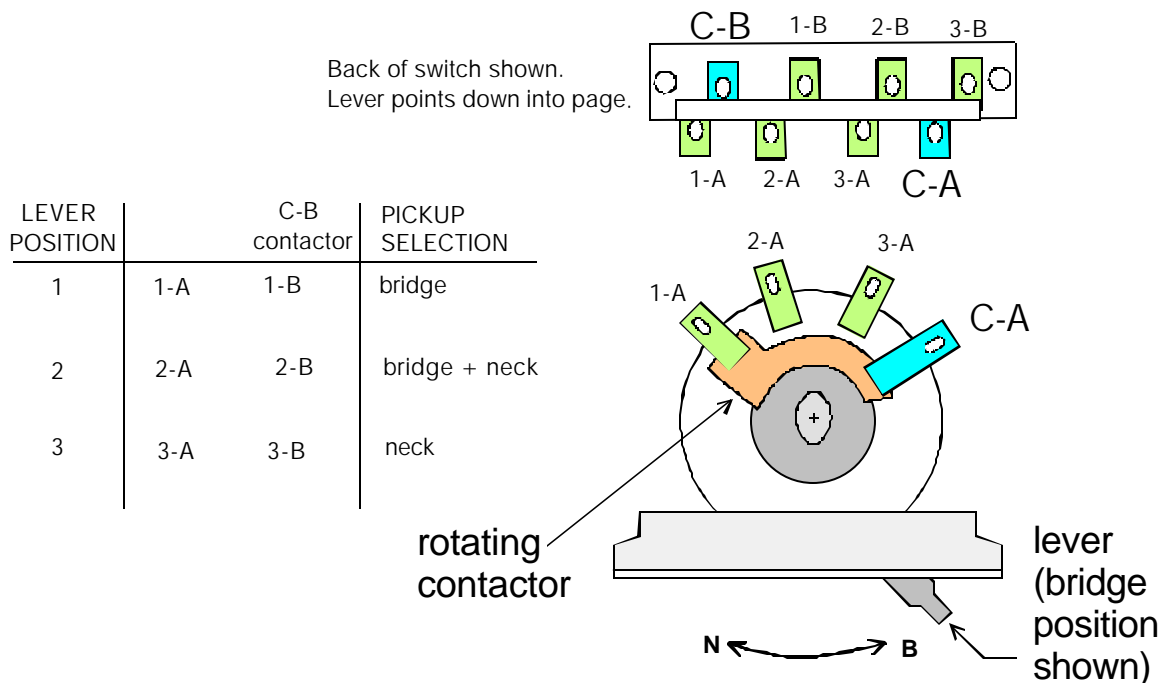

**The 3-position Gibson-style toggle switch is shown below.** As with the 3-position CRL switch, the ORANGE wire of the 10-pin connector goes to the neck pickup terminal of the pickup selector. **The 3-position ON/ON/ON mini toggle switch** functions identically to the Gibson-style toggle, when hooked up with jumper wires as shown in the diagram.

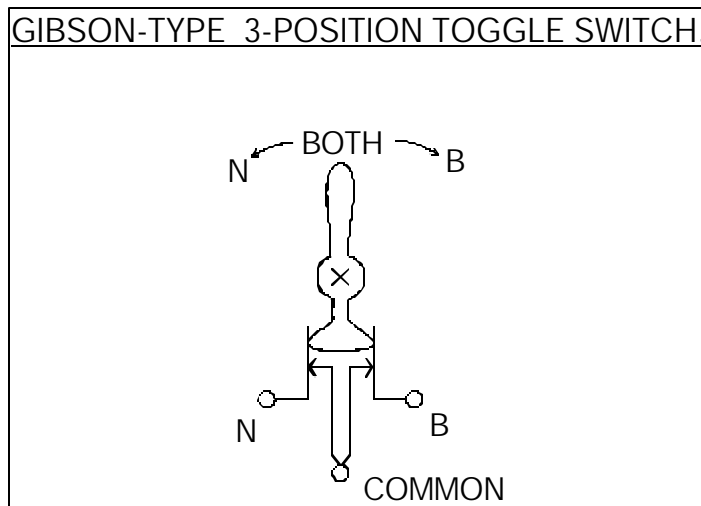

DPDT, ON-ON-ON TOGGLE SWITCH

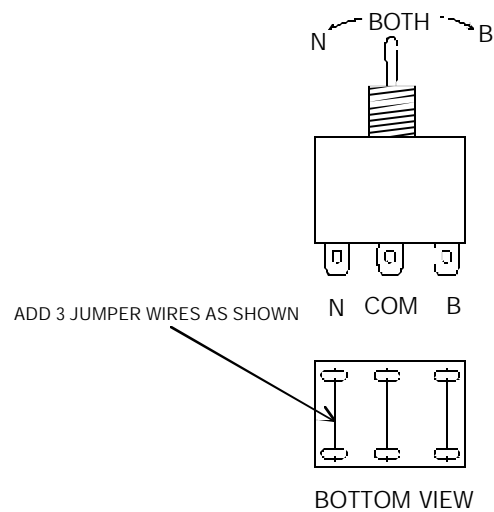

**The 5-position, 4-pole SUPERSWITCH and the 5-position, 4-pole VLX-91** switch are electrically identical to each other, but mechanically different. The 4-pole construction allows you to use coil taps, and other interesting things such as series/parallel bridge humbucker hookup. Each section switches independently. In each switch position 1,2,3,4,5, the rotating contact is connected to its respective numbered contact.

The SUPERSWITCH contacts are mechanically like the CRL switch: A redundant pair of contacts sandwiches the rotating COMMON contactor. This makes the Superswitch very reliable. The VLX-91 switch doesn't have this redundant contact feature. But it does use gold-plated contacts. The neat thing about the VLX-91 is that it occupies the same space as the CRL 2-pole switch. Therefore, the VLX-91 makes a good 4-pole switch because it allows the Sustainiac Stealth PLUS board to fit in between the pickup selector and volume/tone controls on Ibanez Jem etc. with only a tiny bit of routing being necessary.

**USING 4-POLE PICKUP SELECTOR SWITCHES FOR INSTALLATION OF THE SUSTAINIAC, FOR GUITARS HAVING COIL TAPS**

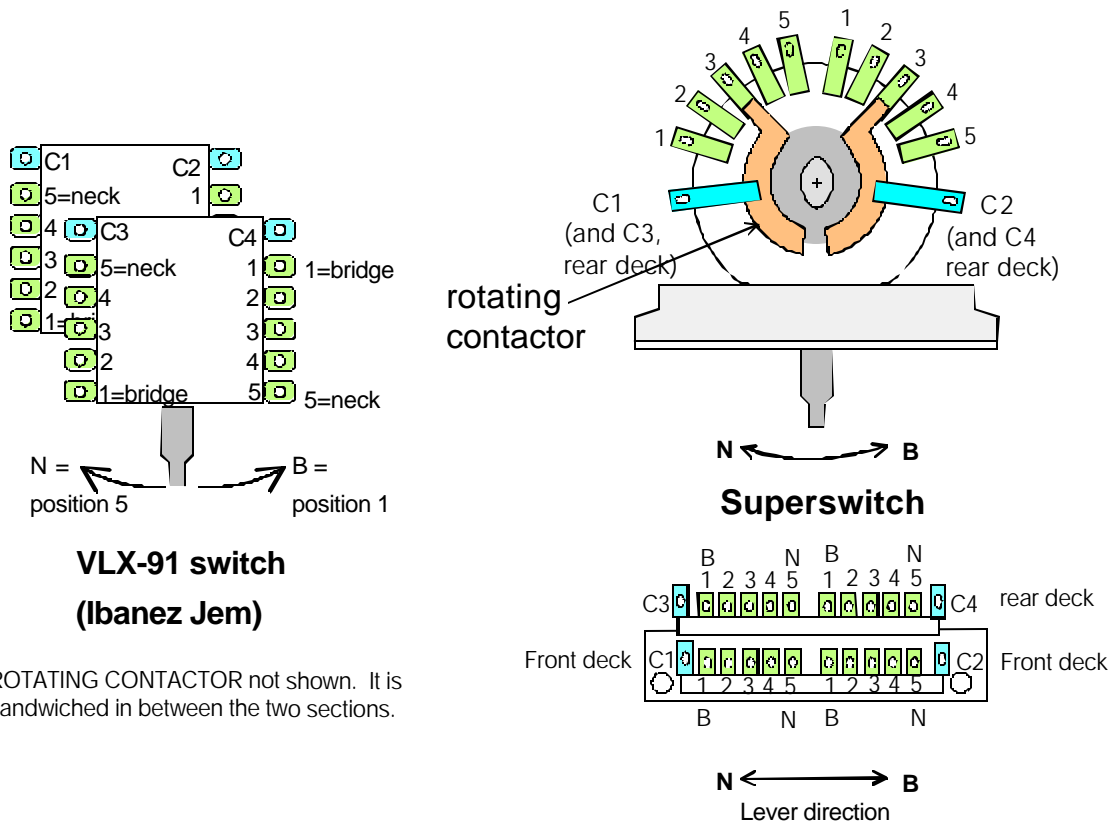

## HOW VOLUME AND TONE CONTROLS WORK:

Refer to the drawings below, showing volume and tone controls. We have shown these in both schematic and pictorial formats. Schematics make more sense once you get used to the way they look. A resistor is drawn simply as a zig-zag line.

Both volume and tone controls use a potentiometer (“pot”). A pot is a 3-terminal resistor with a sliding contactor, or *wiper*. The wiper moves from end-to-end of the resistor. Most electric guitars use 250K or 500K pots. The resistance is measured between the two outside terminals. Guitars with single-coil pickups tend to use 250K pots, guitars with humbucker bridge pickups use 500K pots. EMG active pickups generally use 25K pots, which can drive a signal down longer cords with little or no high frequency loss because of their lower resistance. However, if you connect a 25K pot to a passive pickup, it will sound too “thin”.

Most pots are of the rotating type, having a shaft with a knob on it. The resistive element is a chemical deposit that is arranged in a circular pattern, like a doughnut that isn’t completely closed. Pots having linear sliders, like you see on graphic equalizers, have straight resistive elements, and the slider moves in a linear fashion. The two ends of the resistive element have electrical contacts attached to them. The wiper is connected to the third contact.

The wiper physically touches (wipes against) the resistive element of the pot. When rotated full *counterclockwise* (CCW), the wiper connects to one end of the pot. When rotated full *clockwise* (CW), the wiper connects to the other end of the pot. The schematic shows the “donut” construction of the resistive element.

VOLUME CONTROLS: With a volume control, the CCW end is connected to guitar ground. The CW end is connected to the pickup selector guitar output terminal. The wiper terminal is connected to the output jack. So, when you rotate the wiper full CCW, the control is turned all the way down. The wiper is then physically connected to guitar *ground*, which is zero volts. When you rotate the wiper full CW, the control is turned all the way up, because the guitar output is connected directly to the pickup output.



VOLUME CONTROL  
(POTENTIOMETER, OR  
VARIABLE RESISTOR)

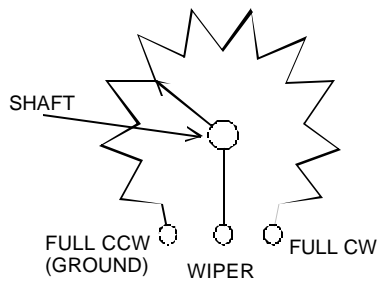
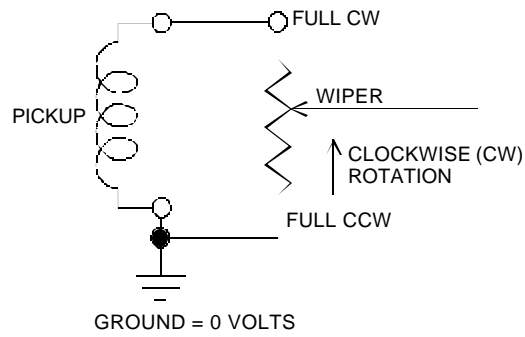

FRONT VIEW OF POT  
(SHAFT FACING OUT OF PAGE)

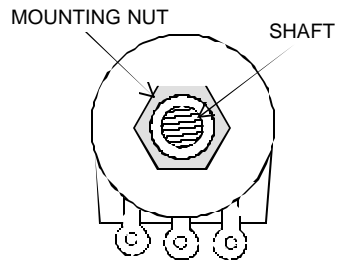

FRONT VIEW OF POT  
(SHAFT FACING OUT OF PAGE)

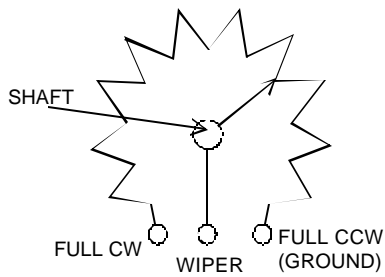

REAR VIEW OF POT  
(SHAFT FACING INTO PAGE)

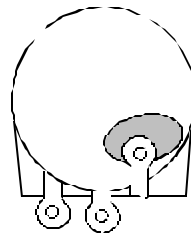

REAR VIEW OF POT  
(SHAFT FACING INTO PAGE)  
Ground lug shown soldered to pot body.

**TONE CONTROLS:** A tone control for most passive pickups uses a capacitor of between 0.022 to 0.1  $\mu\text{F}$  value. The abbreviation “ $\mu\text{F}$ ” means “microfarads” (one millionth of a Farad), the standard unit of capacitance. Capacitors of this value range, when used with most passive pickups, will selectively filter out high audio frequencies, leaving the low frequencies free to pass, when they are connected from the pickup output to ground. The higher the capacitance, the lower the frequency that will be filtered out.

Refer to the TONE CONTROL drawing below: When you rotate the tone control pot to full CCW rotation, the capacitor is connected directly between the pickup output and ground. At full CW rotation, the tone control resistance is between ground and the capacitor, which effectively disconnects the capacitor from ground, allowing full frequency response of the pickup. There are a couple of different ways to hook up a tone pot, which actually produce identical electrical results. The important thing is that at full CCW rotation, the capacitor is connected between the pickup output and ground. At full CW rotation, the full resistance of the pot is between the pickup output and the capacitor, effectively defeating the tone control.

### **TONE CONTROL**

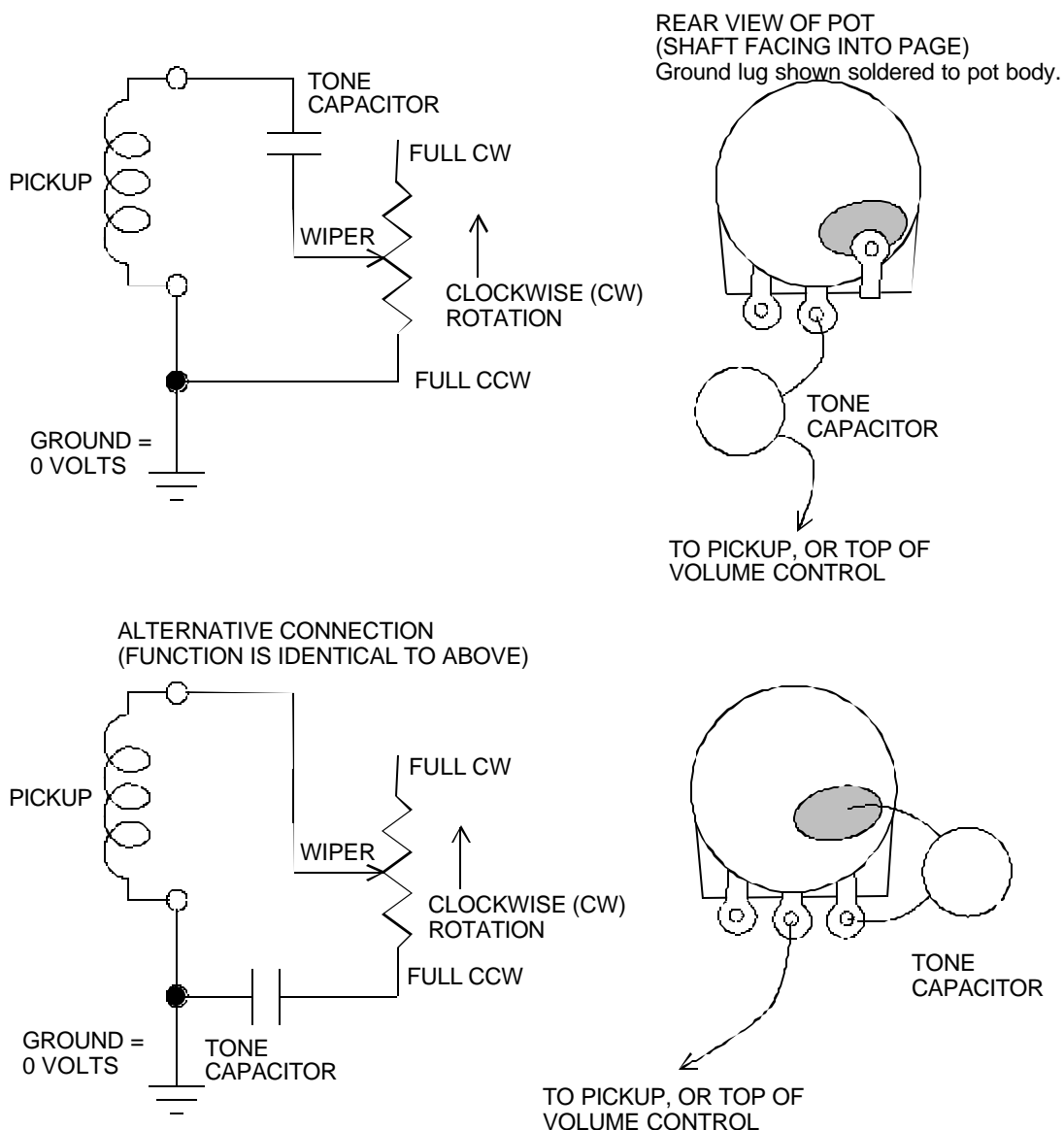

## TYPICAL VOLUME/TONE SETUP

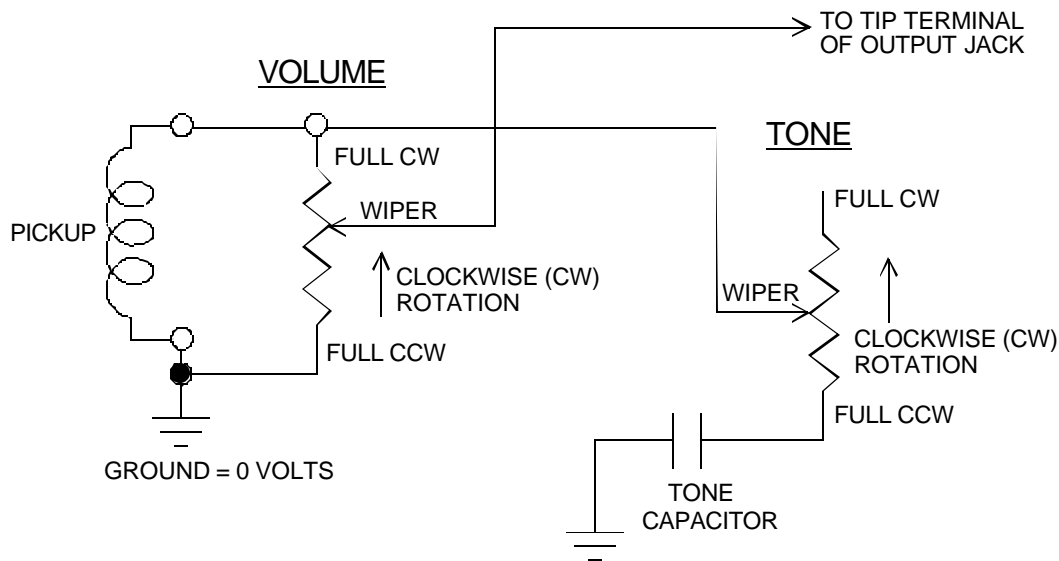

1. Duncans have green=ground, black=output, red/white=tap. You might want to check the Duncan website for this, but I believe it is true.
2. Most Dimarzio's have green=ground, red=out, black/white=tap. But, Dimarzio's are not all consistent.
3. Transducer resistance is 2 ohms (not K ohms!), which is very difficult to measure accurately without a good meter. It is a very low resistance. If you get 4 ohms, then one coil is open.

The best way to test pickups (and the Sustainiac driver) is to use an "old-fashioned" analog microammeter. I mean one that has a moving needle, not a digital one. It must have 50 or 100 uA (micro amperes) full-scale. Many analog multimeters have 50-100 uA full scale on their most sensitive setting.

You simply connect the (-) and (+) meter leads to either side of a coil. If you get no reading, then the two wires are not the start/finish wires of the same coil. You will get either a (+) or (-) needle deflection if you connect across a pickup coil, then touch a screwdriver to the magnetic polepieces, and rapidly pull the screwdriver blade away. I call this the "negative (or positive) on pullaway test". With this test you determine the pickup polarity. Of course, it is easiest to separate the wires of each coil by a resistance test. However, this doesn't tell you anything about polarity, or which wires belong to which coil.

One caution: When you do the screwdriver pullaway test, and you touch a polepiece of one coil with the screwdriver blade, make sure that the shaft of the blade does not extend over a polepiece of the other coil. Otherwise, you will also get a reading from this coil due to magnetic proximity of the screwdriver shaft. Make sure the shaft extends away from the other coil of the pickup (or Sustainiac transducer).

Duncans are all negative-on-pullaway when the (+) meter wire is connected to the black wire, and the (-) meter wire is connected to the green wire. The Sustainiac transducer coils are both positive-on-pullaway. If you don't get a reading on one coil, then the coil wire is broken or unsoldered, etc.

The new "best way" to remove the magnets is to simply take the transducer and bang the bottom against a hard surface like concrete. Or, the jaw of a large steel vice etc. That usually pops them loose without damaging anything. I would sell you a transducer for \$60.