

PARKER FLY/SUSTAINIAC STEALTH PLUS INSTALLATION

Enlarge cavity with router as shown by dotted line

BACK VIEW OF ELECTRONICS CAVITY

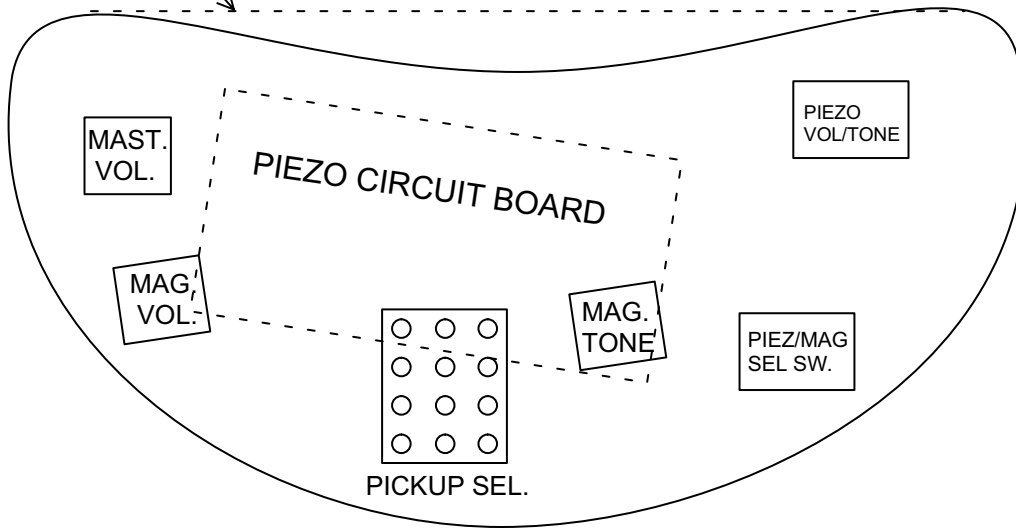

PICKUP SEL. SW
DETAIL BEFORE
SUST. INSTALLTION

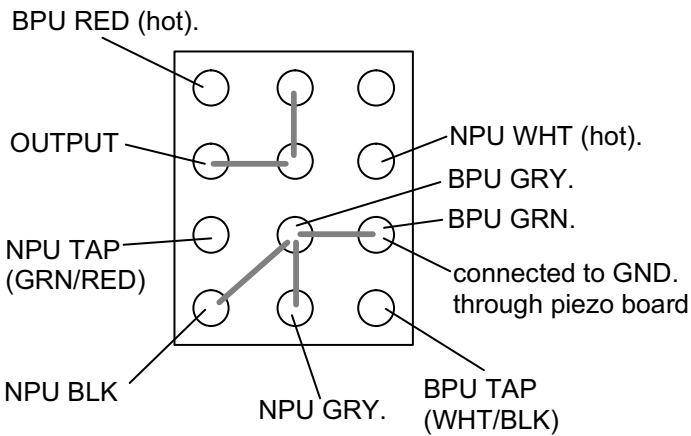

PICKUP SEL. SW
DETAIL SHOWING
SUST. INSTALLTION
(Sust. wires = "S")

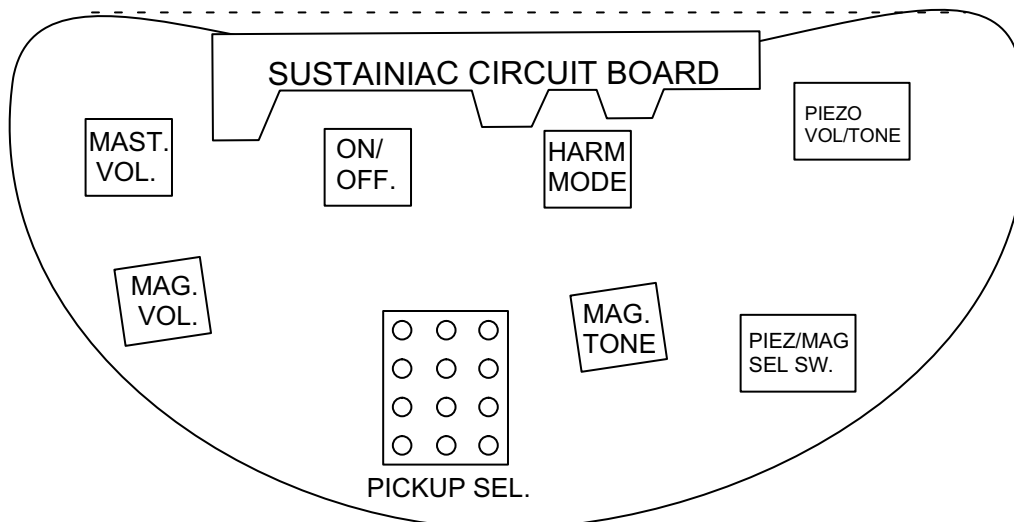
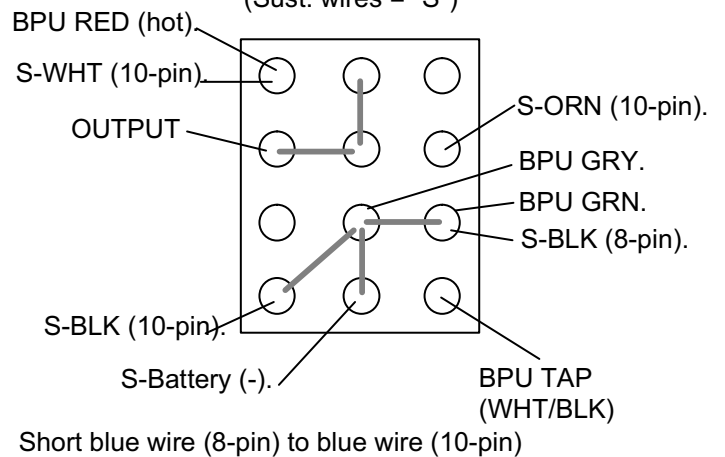

Electronics cavity showing location of Sustaiac circuit board and Sustaiac control switches

"TRS" OUTPUT JACK CONNECTION TO FISHMAN FLEXIBLE CIRCUIT BOARD IN FLY GUITAR

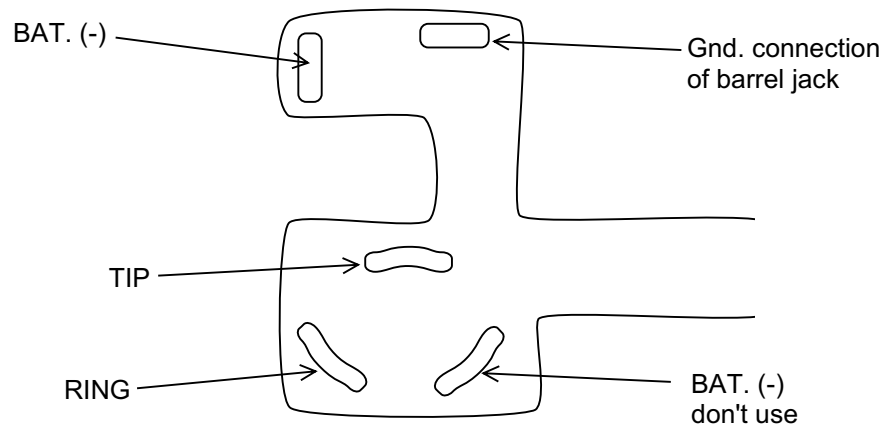

1. Unsolder Fishman circuit board, remove connectors and piezo wires.
2. SEE DRAWING: Unsolder TRS (guitar output, TRS=TIP/RING/SLEAVE) connector and remove it. You need a good "solder-sucker" tool to do this. Otherwise, you will damage the flexible circuit board.
3. Remove neck pickup, also piezo volume and tone pots.
4. Remove the brass "bosses" (anchors) that hold the neck pickup. You will have to insert screws (#6-32) and pry the bosses out.
5. Route the neck pickup cavity to about 0.75 inch (20mm) depth. It will be about 1/16 in. (1.5 mm) from the bottom of the boss hole on the big E-string side, and about 3/16 (4.5mm) in from the bottom of the little E-string side. You want the driver to be about 1/16 in. (1.5 mm) from the little E-string and about 3/16 (4.5mm) in from the big E-string. TAKE GREAT CARE TO GET IT RIGHT.
6. Drill two 1/8 inch (3mm) holes through the bottom of the guitar to mate with the threaded holes in the driver baseplate. Two #4-40 flat head screws are provided to hold the driver to the bottom of the neck pickup cavity. Flare the holes to match the flat head of the screws so that they are flat against the back of the guitar. You can use the thin foam provided to make up for slight routing error. Glue the "dummy" cover to the driver cover using super glue. The dummy cover is sanded on one side to help the glue get a good grip.
7. Route the electronics cavity as shown to make room for the Sustainiac Stealth Plus circuit board. The board will lay on its side in the cavity. Route just deep enough for the circuit board to clear the cavity cover. The body is very thin here, SO BE CAREFUL.
8. Drill or route the original TRS jack hole to fit the 9-pin jack. You will need to add a jack-plate to the side of the guitar body. You can get it from us or from Allparts.
9. When you install the 9-pin jack, you will connect its TIP and RING terminals to the corresponding holes on the flexible circuit board as shown above. You can then use two of the switches on the 9-pin jack to connect both the piezo battery (-) to ground and the Sustainiac green wire to ground. See 9-pin jack hookup diagram.

